

Tennessee Comprehensive
Assessment Program

TCAP

Geometry
Practice Test
Subpart 1, Subpart 2, & Subpart 3

Student Name

Teacher Name



Published under contract with the Tennessee Department of Education by Questar Assessment Inc., 5550 Upper 147th Street West, Minneapolis, MN 55124.
Copyright © 2016 by Tennessee Department of Education. All rights reserved. No part of this publication may be copied, reproduced, or distributed in any form or by any means, or stored in a database or retrieval system, without the prior express written consent of the Tennessee Department of Education and Questar Assessment Inc.

Test Administrator Instructions:

This practice test has Subpart 1, Subpart 2, and Subpart 3. There is also an answer document and an answer key at the end of this document. It is recommended that you print one copy of this practice test and pull the answer key before copying and distributing the practice test and answer document to your students.

This practice test is representative of the operational test but is shorter than the actual operational test. To see the details about the operational test, please see the blueprints located on the Tennessee Department of Education website.

Subpart 1 of this Practice Test booklet contains constructed-response items and selected-response items in Geometry. Write all answers on your answer document.

You MAY NOT use a calculator in Subpart 1 of this test booklet.

Sample 1: Constructed-Response

1. In triangle RST , $m\angle R = 15^\circ$ and $m\angle S = 50^\circ$. What is the measure, in degrees, of $\angle T$?

Write your answer in the space provided on your answer document.

Sample 2: Selected-Response

2. Given: $\triangle RST \sim \triangle JKL$, $\overline{RS} = 8$ centimeters, $\overline{JK} = 16$ centimeters, and $\overline{KL} = 14$ centimeters.

What is the length, in centimeters, of \overline{ST} ?

- A. 6
- B. 7
- C. 22
- D. 24



1. Triangle RST and triangle $R'S'T'$ are shown.

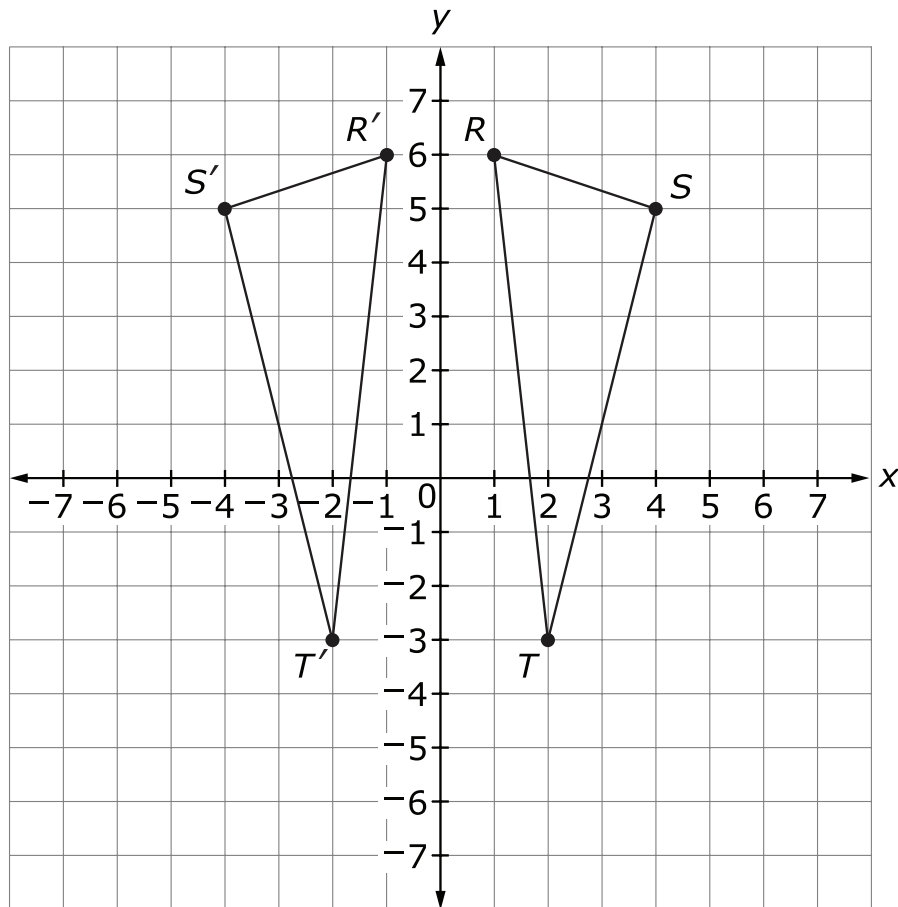

For which transformation would triangle RST have image $R'S'T'$?

- A. a 180° rotation
- B. a translation left 8 units
- C. a reflection over the y-axis
- D. a reflection over the x-axis



2. Isosceles trapezoid $RSTU$, with K as midpoint of \overline{RS} , L as midpoint of \overline{ST} , M as midpoint of \overline{TU} , and N as midpoint of \overline{RU} , is shown. Point P is the intersection of \overline{KM} and \overline{NL} .

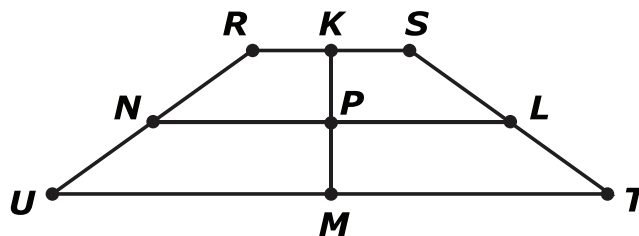

Which transformation carries the trapezoid onto itself?

- A. a 90° rotation clockwise about P
- B. a 180° rotation clockwise about P
- C. a reflection over \overline{KM}
- D. a reflection over \overline{NL}



3. The rectangular prism below is cut in half by the dotted line shown, after which the two halves are separated.

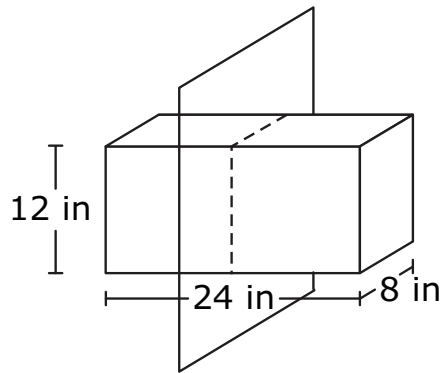

Which of these rectangles represents the cross-sectional cut of each half of the prism?

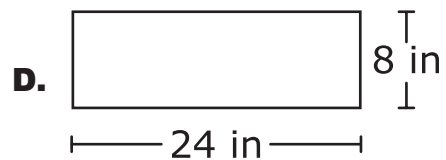
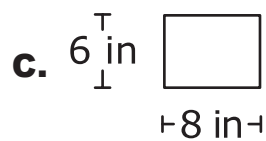
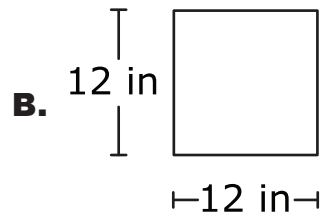
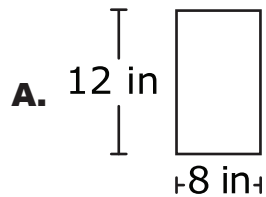



4. In the diagram shown, line l is parallel to line m , and lines n and p intersect at a point on line m .

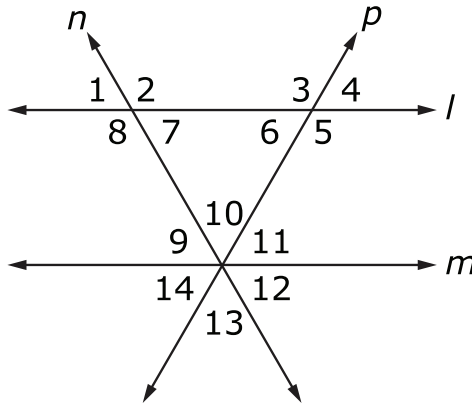

Mark the phrase or value that **best** completes each statement shown on your answer document.

Angle 6 is congruent to angle 11 because they are

- vertical angles
- alternate interior angles
- corresponding angles

The sum of the measures of angles 4, 7, and

- 2
- 5
- 10

is equal to 180° .



5. Shanika is making a decorative tablecloth for her small circular table. The table has a radius of 40 centimeters and height of 60 centimeters. She wants the tablecloth to hang an even 10 centimeters above the ground.

Which design would give Shanika what she wants?

- A.** a circular piece of cloth with a radius of 90 cm
B. a circular piece of cloth with a radius of 110 cm
C. a rectangular piece of cloth with a length of 50 cm and a width of 40 cm
D. a rectangular piece of cloth with a length of 60 cm and a width of 50 cm
6. The three line segments dividing the two sides of the triangle shown are parallel to the base of the triangle.

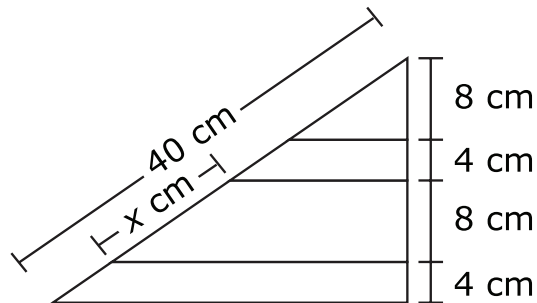

Which proportion can be used to find the value of x ?

- A.** $\frac{1}{4} = \frac{x}{8}$
B. $\frac{1}{4} = \frac{8}{x}$
C. $\frac{24}{40} = \frac{x}{8}$
D. $\frac{24}{40} = \frac{8}{x}$



7. Determine which statement is true in regard to $\triangle ABC$ and $\triangle LMN$.

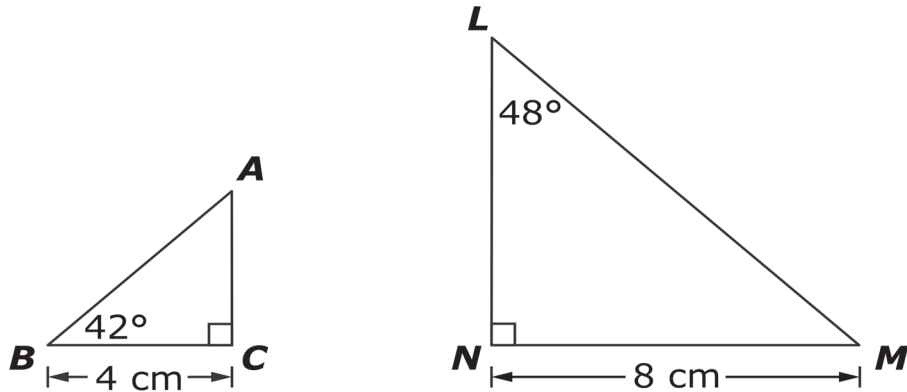

- A. $\triangle ABC \sim \triangle LMN$ by AA criterion.
 - B. $\triangle ABC \sim \triangle LMN$ by SAS criterion.
 - C. $\triangle ABC \sim \triangle LMN$ by SSS criterion.
 - D. $\triangle ABC$ and $\triangle LMN$ are not similar.
8. The triangles QTP and SPT are shown. Line RM is the perpendicular bisector of line segment PT and intersects line segment PT at point M .

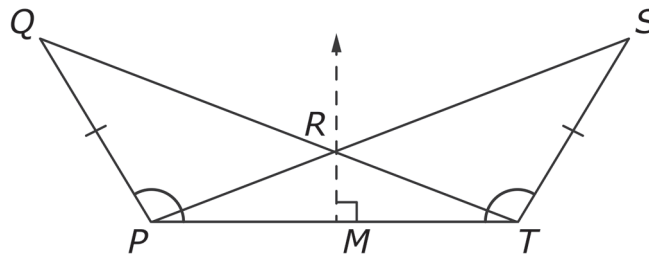

Which transformation would imply that $\triangle QTP \cong \triangle SPT$?

- A. horizontal translation the length of \overline{PR}
- B. horizontal translation the length of \overline{PT}
- C. reflection over \overline{RM}
- D. reflection over \overline{SP}



9. For $\triangle RST$ and $\triangle UVW$, sides \overline{RS} , \overline{RT} , and \overline{ST} are congruent to sides \overline{VW} , \overline{VU} , and \overline{WU} , respectively.

Which word, phrase, or label **best** completes each statement?

- This proves that there _____ be a set of rigid motions that has pre-image $\triangle RST$ and image $\triangle UVW$.
 - could or could not
 - must
 - cannot
- This also proves that angle RST is congruent to angle _____.
 - UVW
 - VWU
 - WUV

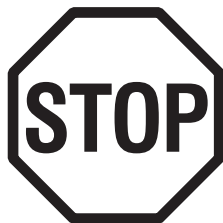

**This is the end of Subpart 1 of the Geometry Practice Test.
Proceed to Subpart 2.**

**Directions**

Subpart 2 of this Practice Test booklet contains constructed-response items and selected-response items in Geometry. Write all answers on your answer document.

You MAY use a calculator in Subpart 2 of this test booklet.

- 10.** For the triangle shown, what is the measure of angle 1?

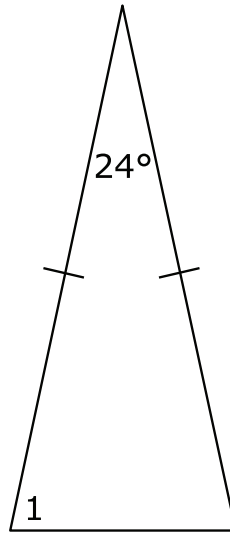

- A.** 24°
- B.** 78°
- C.** 132°
- D.** 156°



11. Create the circumscribed circle for triangle RST with vertices at $R(-3, 6)$, $S(3, 6)$, and $T(3, -2)$ on the grid provided on your answer document.

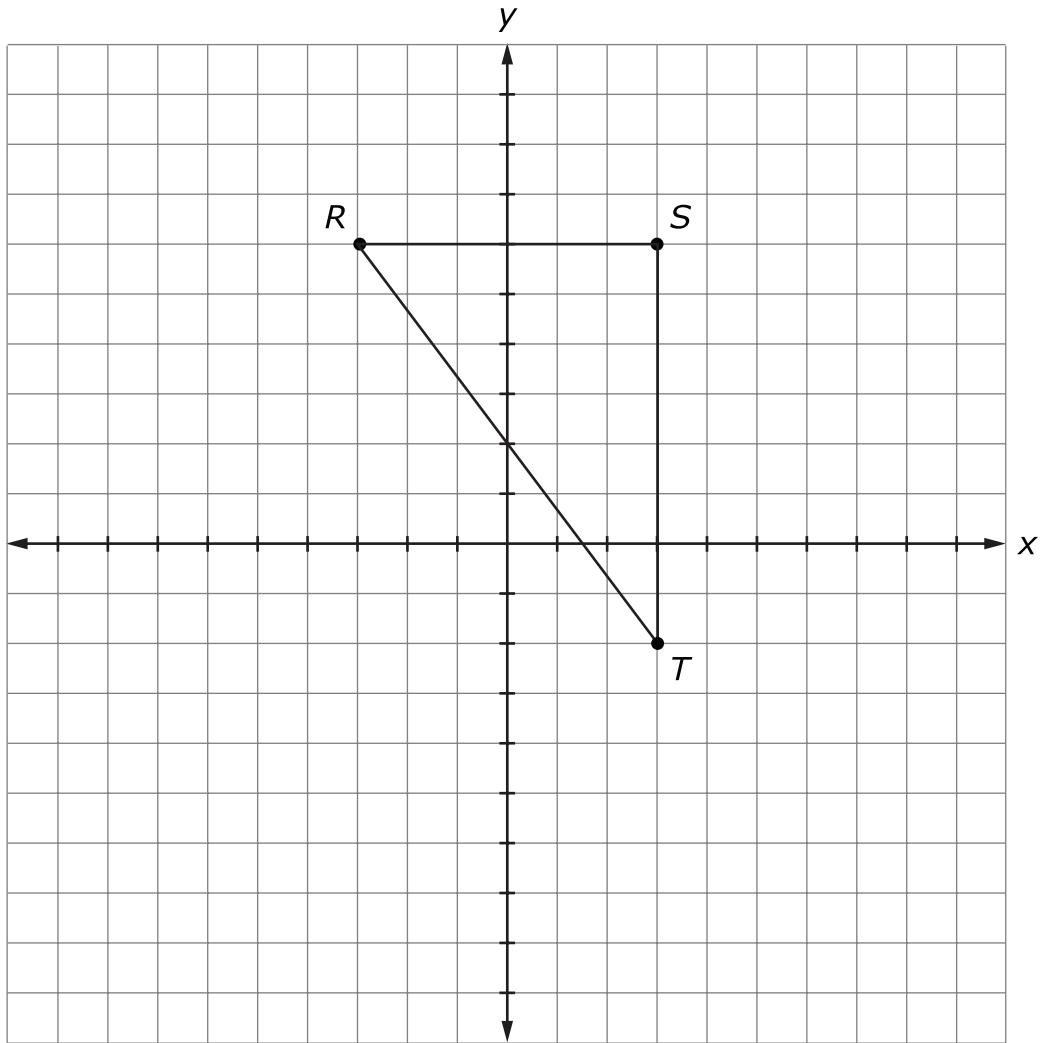



12. In the figure shown, $\cos(w^\circ) = 0.60$.

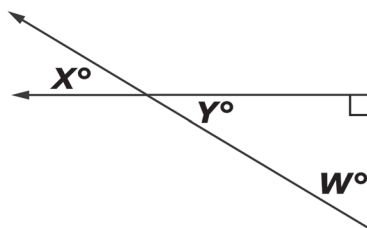

What is $\sin(x^\circ)$?

- A. 0.36
 - B. 0.40
 - C. 0.60
 - D. 0.80
13. $\triangle RSV \sim \triangle UST$

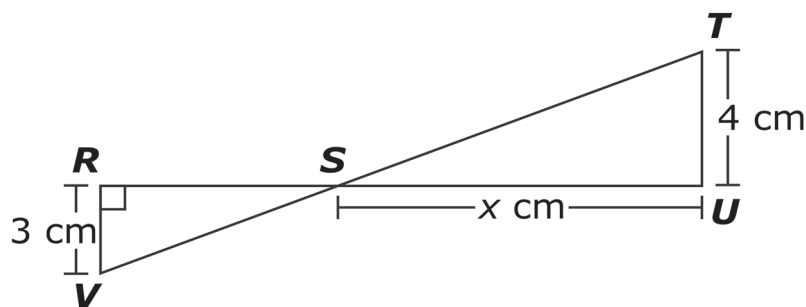

Select **all** statements that are true.

- A. $\triangle STU$ is a right triangle.
- B. \overline{RS} is $\frac{4}{3}x$ cm in length.
- C. $\angle VRS \cong \angle STU$
- D. The area of $\triangle RSV$ is $\frac{9}{8}x$ cm².
- E. $m\angle RSV + m\angle UST = 90^\circ$



14. In the figure, \overline{PS} is tangent to circle O at point S .

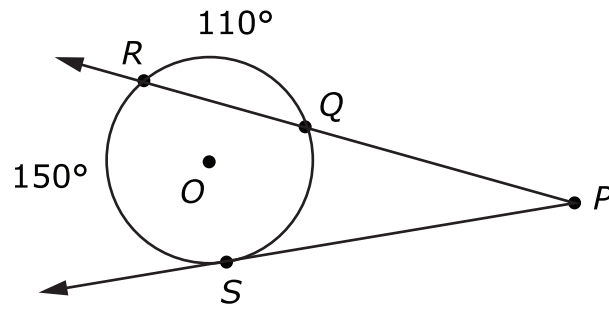

What is the measure, in degrees, of $\angle QPS$?

Write your answer in the space provided on your answer document.



15. The windshield wiper of a car rotates through an angle of measure $\frac{5\pi}{6}$ radians, as shown.

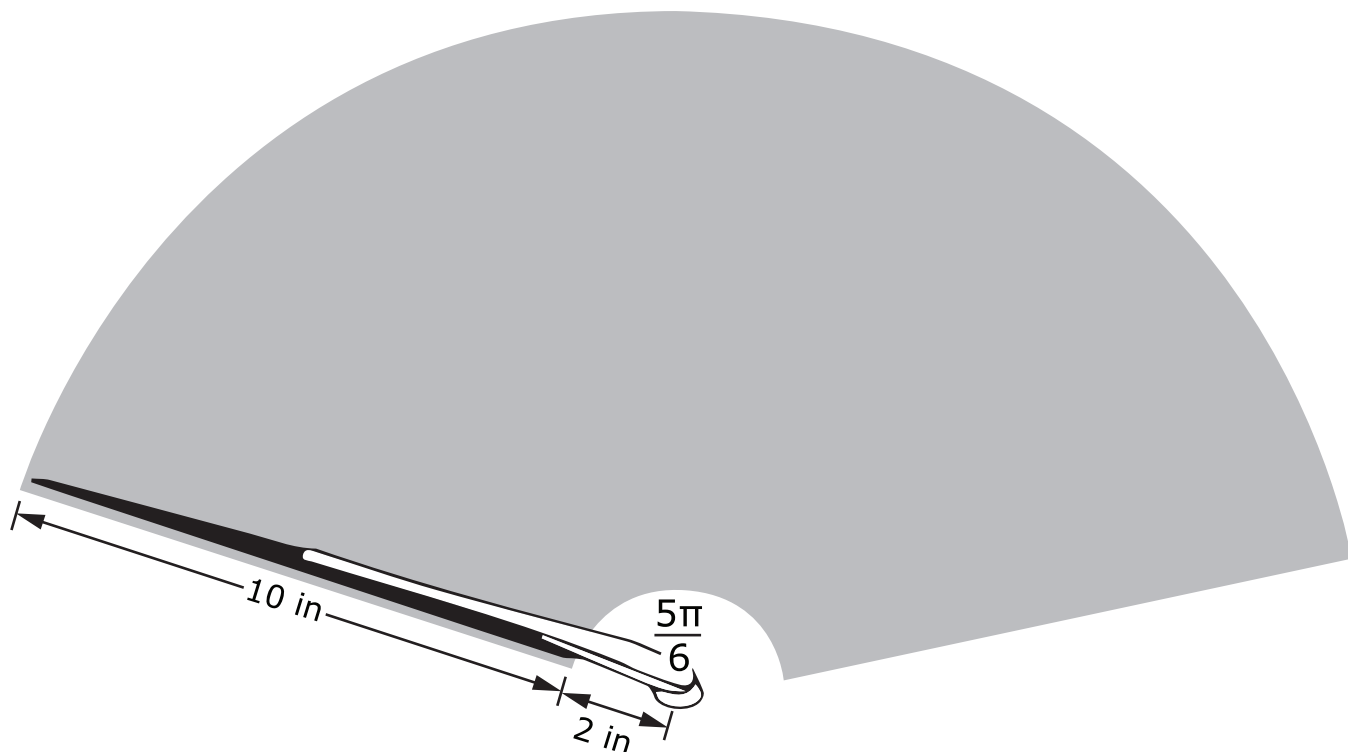

The shaded section of the diagram represents the area cleared by the 10-inch blade of the windshield wiper as it moves from one side to the other. Approximately what is the area cleared by the blade of the windshield wiper?

- A. 125 in²
- B. 183 in²
- C. 367 in²
- D. 790 in²



16. In the figure shown, $\triangle RST \sim \triangle UVW$.

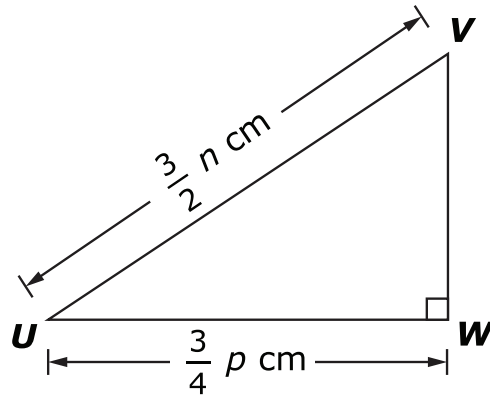
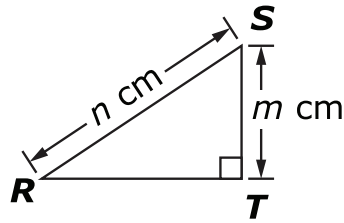

Write an expression that represents $\tan(R)$.

Write your answer in the space provided on your answer document.

17. The Fun Run organizers want to provide cylindrical cups of water to all runners after the race. The cups have a base diameter of 2.5 inches and a height of 5 inches. How much water should the organizers estimate to serve each runner? (Assume each runner will only drink one cup of water.)
- A. 24.5 in^3
 - B. 31.25 in^3
 - C. 39.3 in^3
 - D. 49.11 in^3



18. The two chords shown in the circle intercept the given arcs.

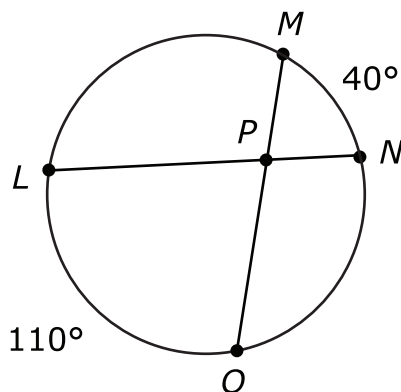

What is the measure of $\angle MPN$?

- A. 70°
 - B. 75°
 - C. 115°
 - D. 150°
19. Parallelogram $RSTU$ is shown. The perimeter of parallelogram $RSTU$ is 50 centimeters.

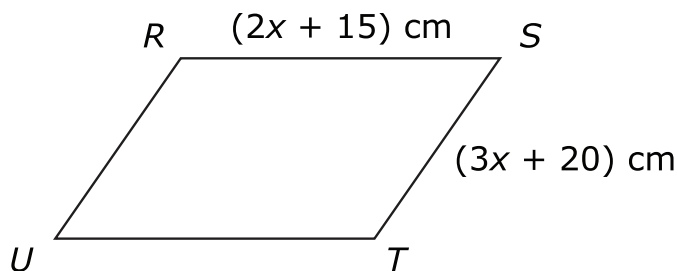

What is the value of x ?

- A. -5
- B. -2
- C. 3
- D. 12



20. Chris is looking up at the top of a tree. He is standing 20 feet from the tree, and his line of sight is 35° from horizontal. His eyes are 5 feet above the ground.

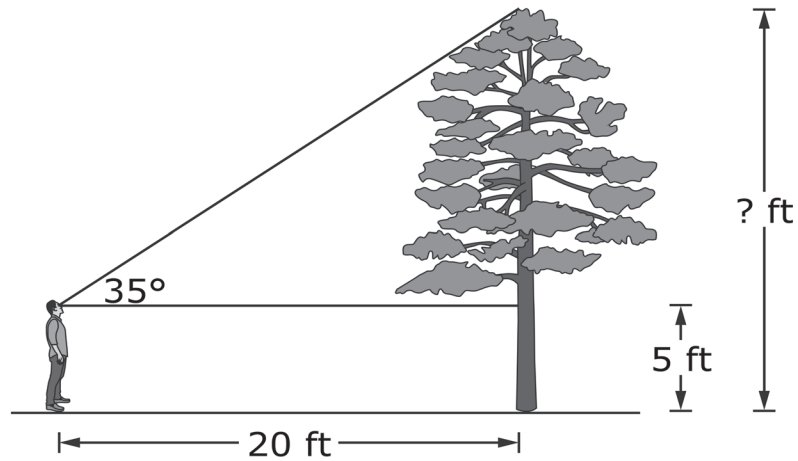

To the nearest foot, how tall is the tree?

Write your answer in the space provided on your answer document.



21. Rectangle $ABCD$ is shown.

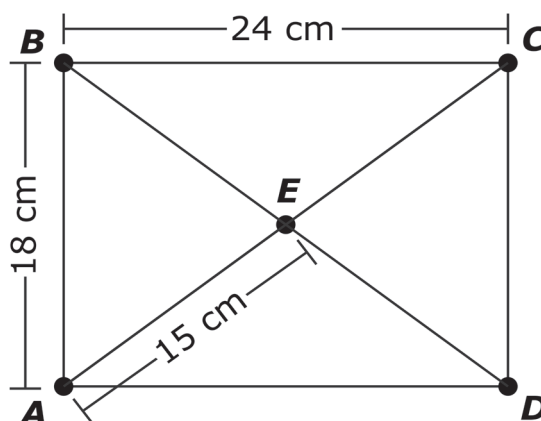

Which value **best** completes each statement?

1. The measure of side CD is _____ cm.
 - A. 15
 - B. 18
 - C. 24
 - D. 30

2. The measure of diagonal BD is _____ cm.
 - A. 15
 - B. 18
 - C. 24
 - D. 30

3. The perimeter of triangle CDE is _____ cm.
 - A. 33
 - B. 48
 - C. 54
 - D. 57



- 22.** A right triangle has leg lengths 0.3 centimeters and 0.4 centimeters. What is $\cos\theta$ where θ is the smallest angle of the triangle?

Write your answer in the space provided on your answer document.



**This is the end of Subpart 2 of the Geometry Practice Test.
Proceed to Subpart 3.**



Directions

Subpart 3 contains constructed-response items and selected-response items in Geometry. For constructed-response items, write your answer in the space provided. Write all answers on your answer document.

You MAY use a calculator in Subpart 3 of this test booklet.



23. A proof is shown.

Given: $\triangle RST \cong \triangle PTS$, $\overleftrightarrow{SP} \parallel \overleftrightarrow{RT}$, and $\overleftrightarrow{SR} \parallel \overleftrightarrow{PT}$

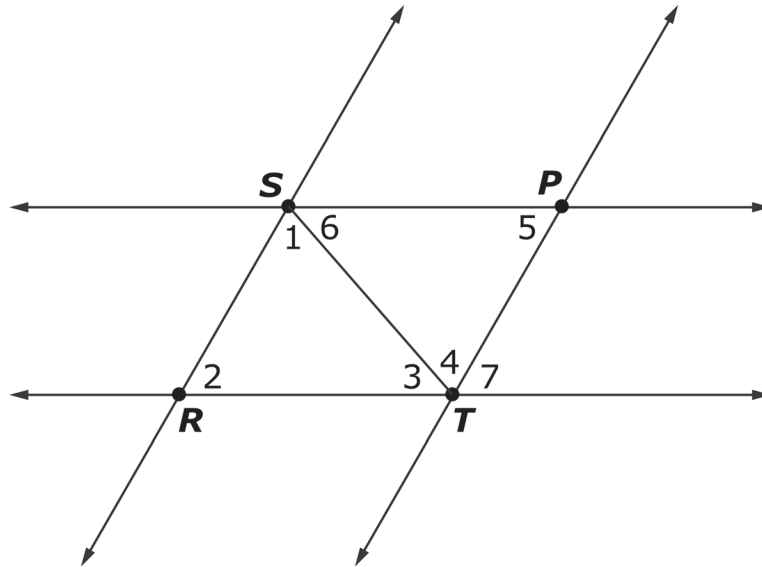

Prove: The sum of the measures of the interior angles of $\triangle RST$ is 180° .

Using the list of reasons provided, mark the correct reason for each statement on your answer document.

Statement	Reason
1. $\triangle RST \cong \triangle PTS$	1.
2. $\angle 1 \cong \angle 4$	2.
3. $\angle 7 \cong \angle 2$	3.
4. $m\angle 4 + m\angle 7 + m\angle 3 = 180^\circ$	4.
5. $m\angle 1 + m\angle 2 + m\angle 3 = 180^\circ$	5.

Reasons:

- A. Substitution
- B. Alternate interior angles are congruent.
- C. Corresponding angles are congruent.
- D. Angles 3, 4, and 7 form a line.
- E. Given



24. Using the coordinate graph on your answer document, graph the line that is parallel to the line with equation $-2x + y = 1$ and that passes through the point $(1, -1)$.

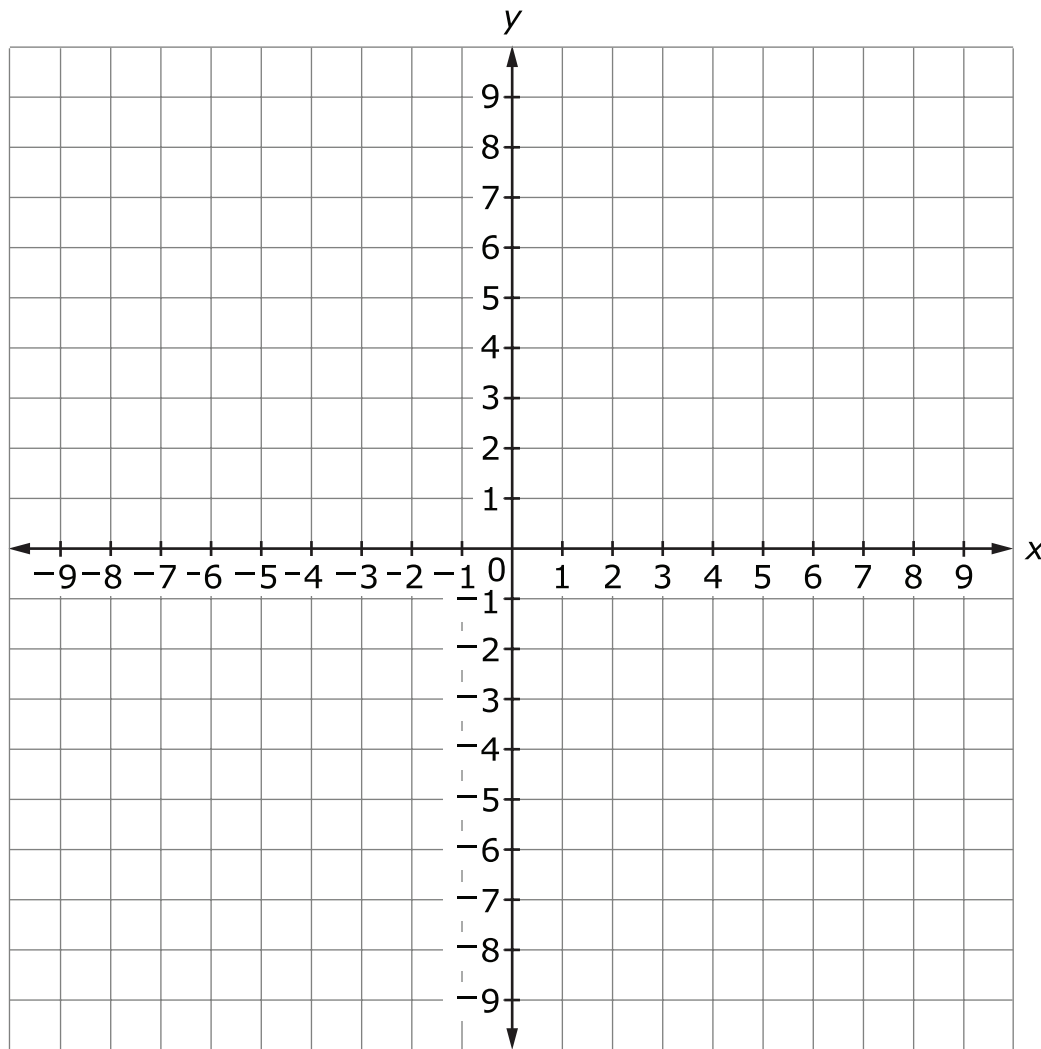



- 25.** A support wire is attached to the top of an antenna. The support wire connects to the ground 15 feet from the bottom of the antenna. The support wire and the ground meet at an angle with measure 70° , as shown.

To the nearest foot, what is the height of the antenna?

Write your answer in the space provided on your answer document.

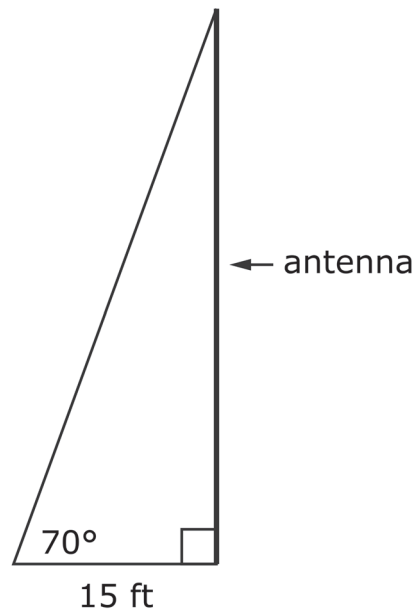



26. Using the coordinate graph on your answer document, create the final image of $\triangle RST$ after reflecting first over the x -axis and then over the y -axis on the grid provided on your answer document.

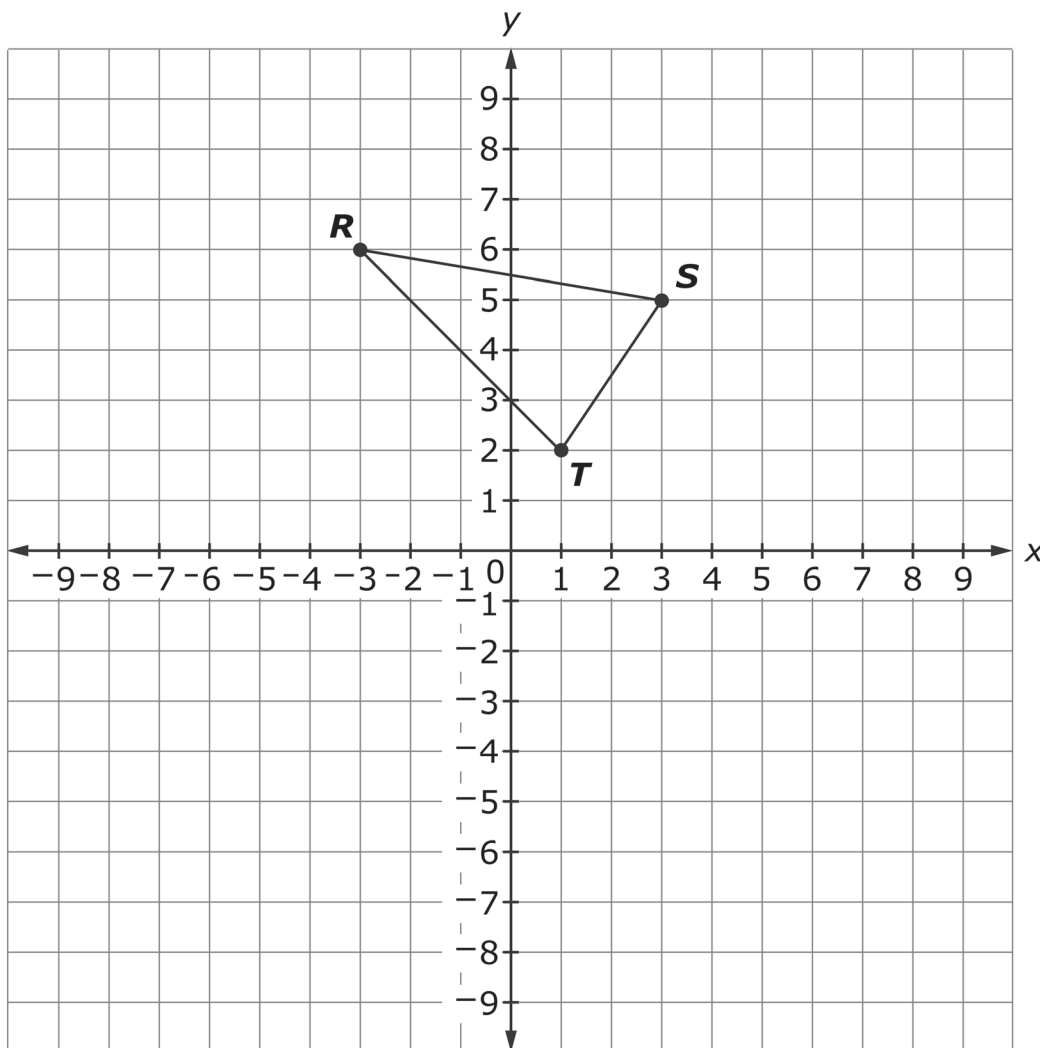



27. Mr. Miller is trying to determine the width of his pond. He makes the measurements shown.

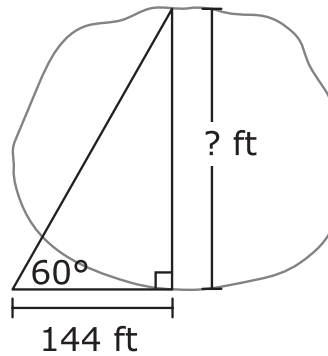

To the nearest foot, what is the width of the pond?

Write your answer in the space provided on your answer document.

28. Quadrilateral $LMNO$ has coordinates $L(5, 6)$, $M(9, 8)$, $N(11, 12)$, and $O(7, 10)$. How can quadrilateral $LMNO$ be classified?
- A. square
 - B. rhombus but not a square
 - C. rectangle but not a square
 - D. parallelogram but neither a rhombus nor a rectangle



29. Using the coordinate graph on your answer document, place the point that is $\frac{2}{3}$ of the way from R to S on the line segment with endpoints $R(-2, -2)$ and $S(4, 1)$.

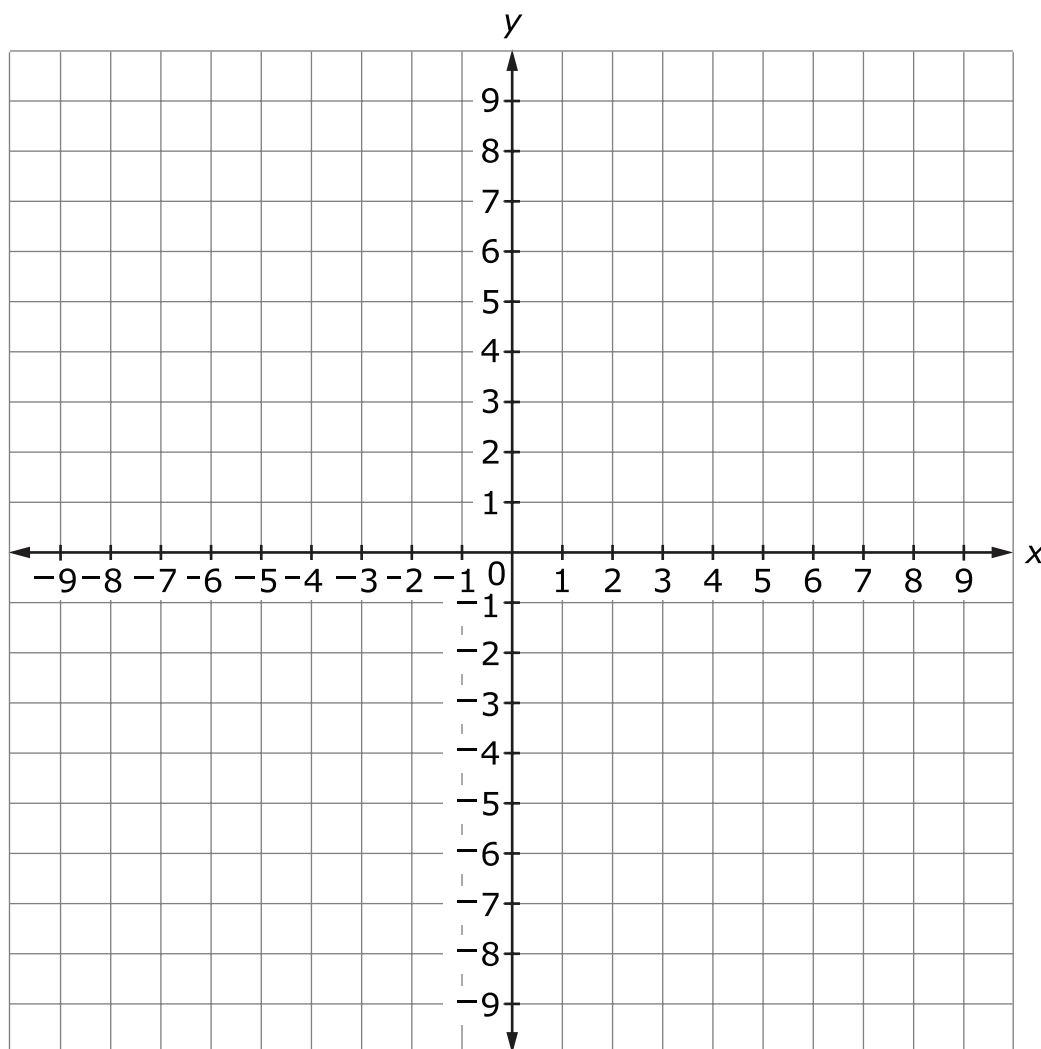



- 30.** $\triangle RST \sim \triangle UVW$. The dilation that maps $\triangle RST$ to $\triangle UVW$ has a dilation factor of $\frac{2}{3}$.

The measure of angle R is 20° , and the measure of angle S is 100° .

What is the measure, in degrees, of angle W ?

Write your answer in the space provided on your answer document.



This is the end of the test.

This page is intentionally left blank.

TNReady Math Reference Sheet—High School

1 inch = 2.54 centimeters

1 meter = 39.37 inches

1 mile = 5,280 feet

1 mile = 1,760 yards

1 mile = 1.609 kilometers

1 kilometer = 0.62 mile

1 pound = 16 ounces

1 pound = 0.454 kilograms

1 kilogram = 2.2 pounds

1 ton = 2000 pounds

1 cup = 8 fluid ounces

1 pint = 2 cups

1 quart = 2 pints

1 gallon = 4 quarts

1 gallon = 3.785 liters

1 liter = 0.264 gallons

1 liter = 1000 cubic centimeters

Pythagorean Theorem: $a^2 + b^2 = c^2$

Quadratic Formula: $x = \frac{-b \pm \sqrt{b^2 - 4ac}}{2a}$

Arithmetic Sequence: $a_n = a_1 + (n - 1)d$

Geometric Sequence: $a_n = a_1 r^{n-1}$

Finite Geometric Series: $S_n = \frac{a_1(1 - r^n)}{1 - r}$

Degrees: 1 degree = $\frac{\pi}{180}$ radians

Radians: 1 radian = $\frac{180}{\pi}$ degrees

This page is intentionally left blank.

Name: _____

Subpart 1 Sample Questions

1.

2. A B C D

Subpart 1 Practice Test Questions

1. A B C D

2. A B C D

3. A B C D

4. vertical angles
 alternate interior angles
 corresponding angles

2
 5
 10

5. A B C D

6. A B C D

7. A B C D

8. A B C D

9. 1. A B C

2. A B C

Subpart 2 Practice Test Questions

10. (A) (B) (C) (D)

11.

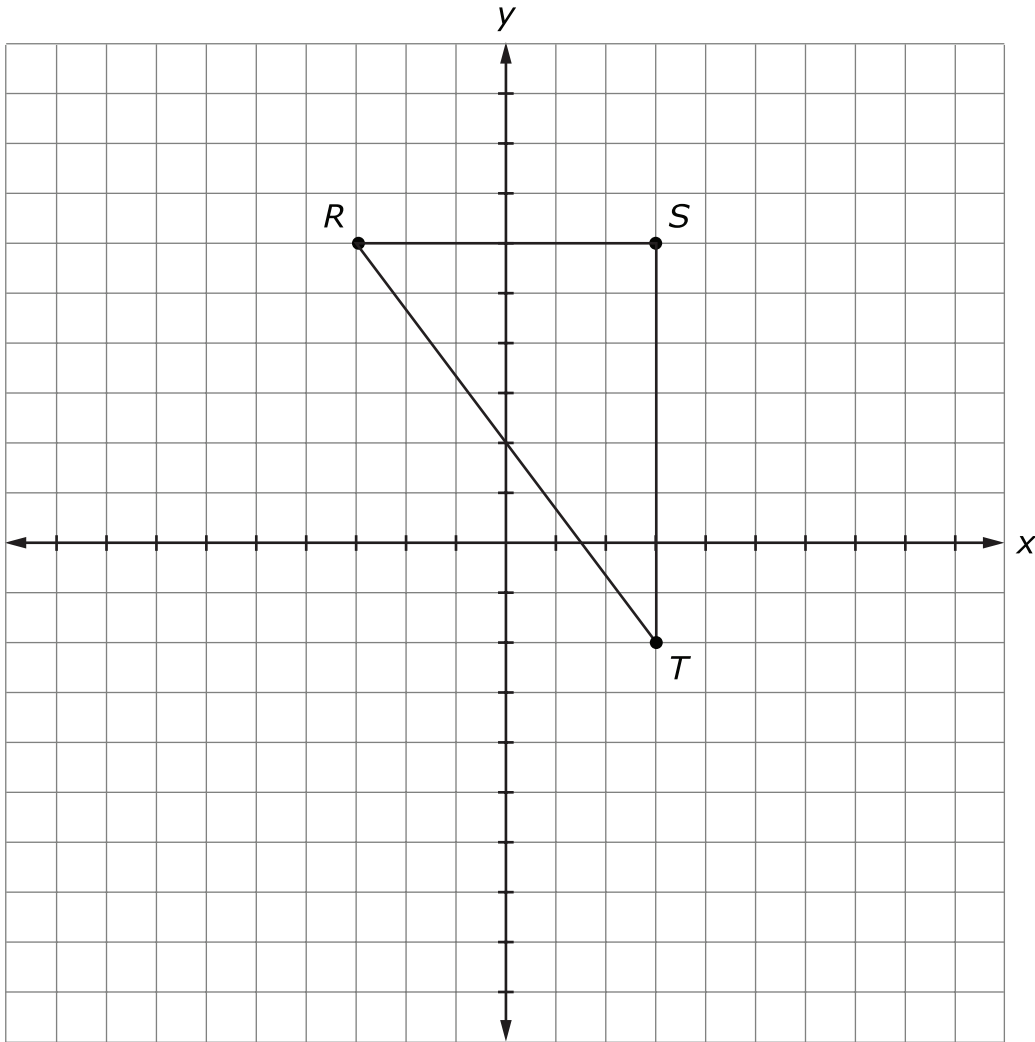

12. (A) (B) (C) (D)

13. (A) (B) (C) (D) (E)

14.

15. (A) (B) (C) (D)

16.

17. (A) (B) (C) (D)

18. (A) (B) (C) (D)

19. (A) (B) (C) (D)

20.

21. 1. (A) (B) (C) (D)

2. (A) (B) (C) (D)

3. (A) (B) (C) (D)

22.

Subpart 3 Practice Test Questions

23. 1. (A) (B) (C) (D) (E)

2. (A) (B) (C) (D) (E)

3. (A) (B) (C) (D) (E)

4. (A) (B) (C) (D) (E)

5. (A) (B) (C) (D) (E)

24.

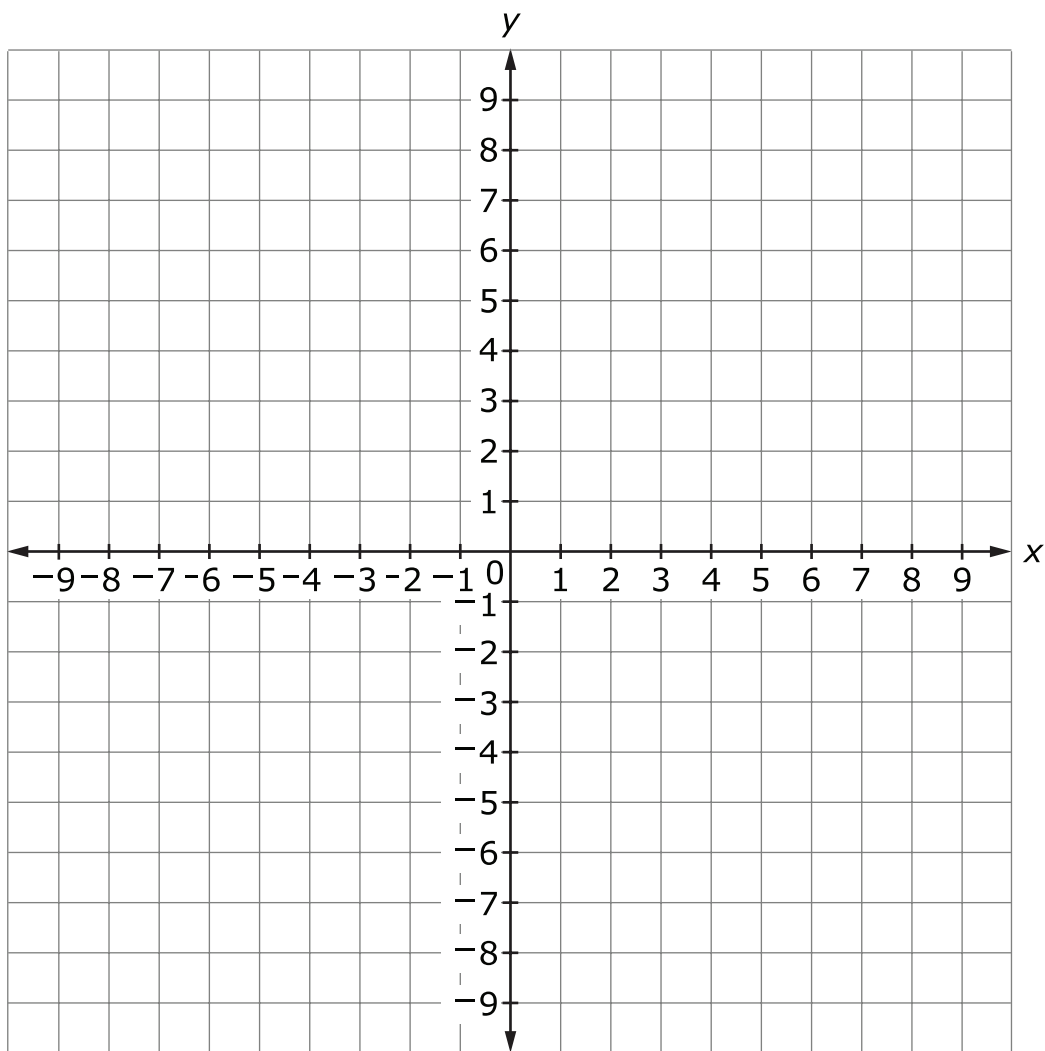

25.

26.

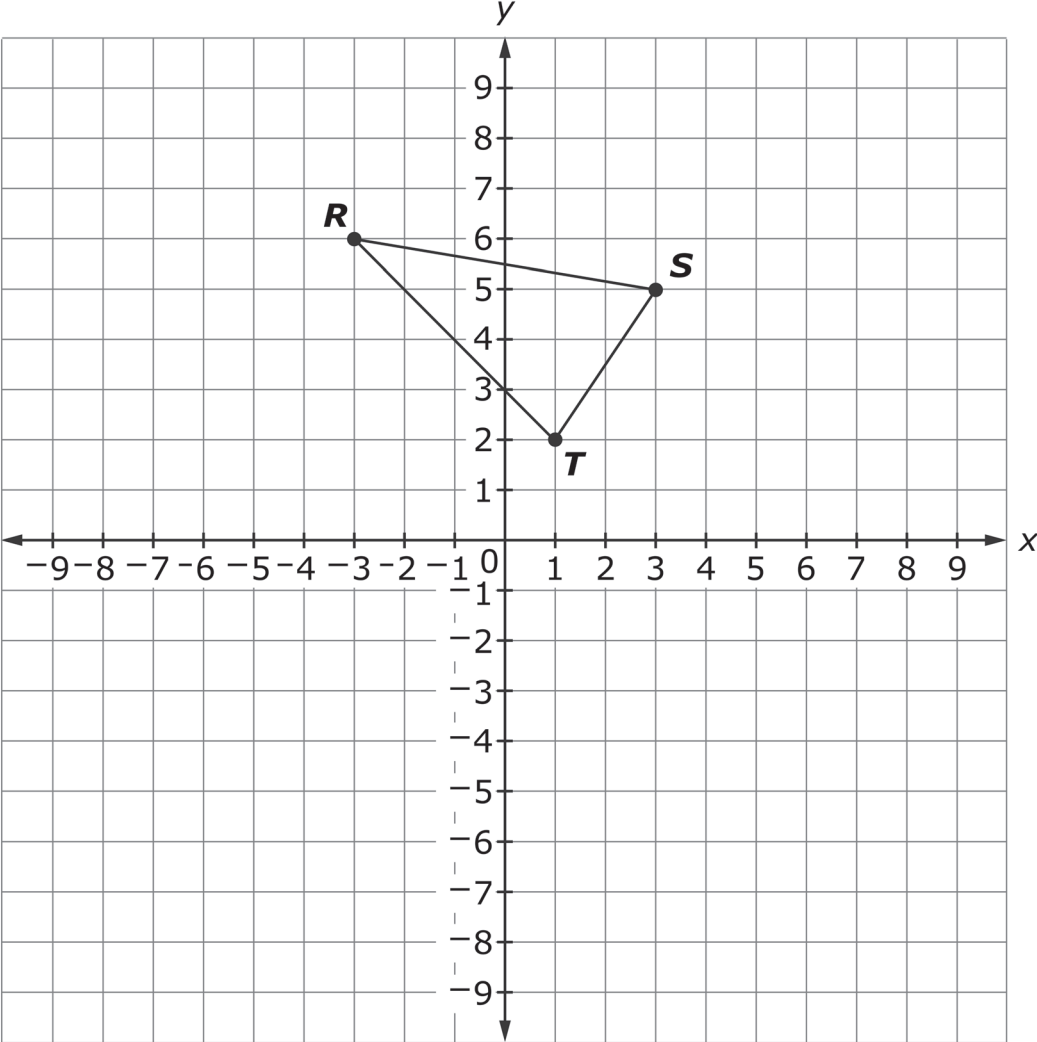

27.

28.

- (A)
- (B)
- (C)
- (D)

29.

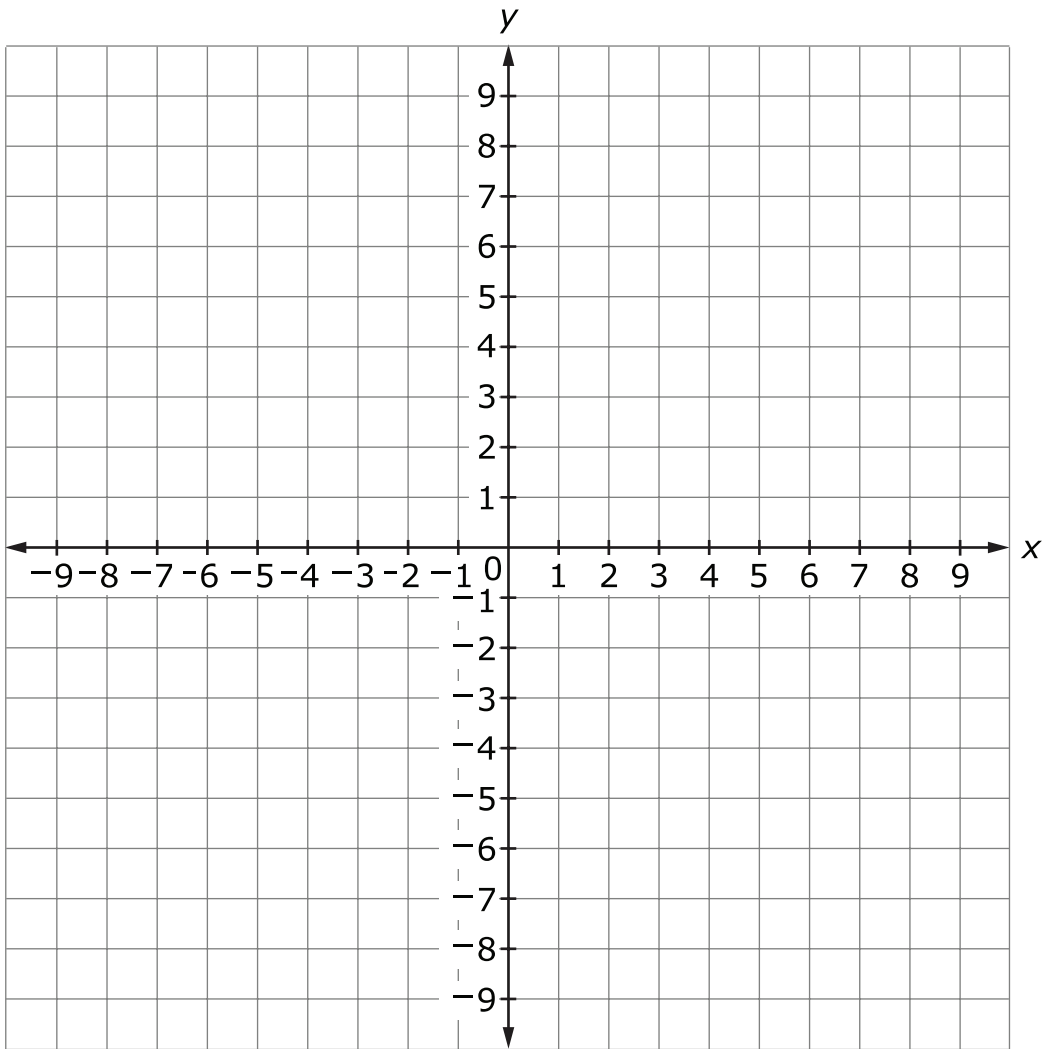

30.

Subpart 1 Sample Questions

1. 115°
 2. (A) ● (C) (D)

Subpart 1 Practice Test Questions

1. (A) (B) ● (D)
 2. (A) (B) ● (D)
 3. ● (B) (C) (D)
 4.

vertical angles
 alternate interior angles
 corresponding angles

2
 5
 10

5. ● (B) (C) (D)
 6. (A) (B) (C) ●
 7. ● (B) (C) (D)
 8. (A) (B) ● (D)
 9. 1. (A) ● (C)
 2. (A) ● (C)

Subpart 2 Practice Test Questions

10. A B C D

11.

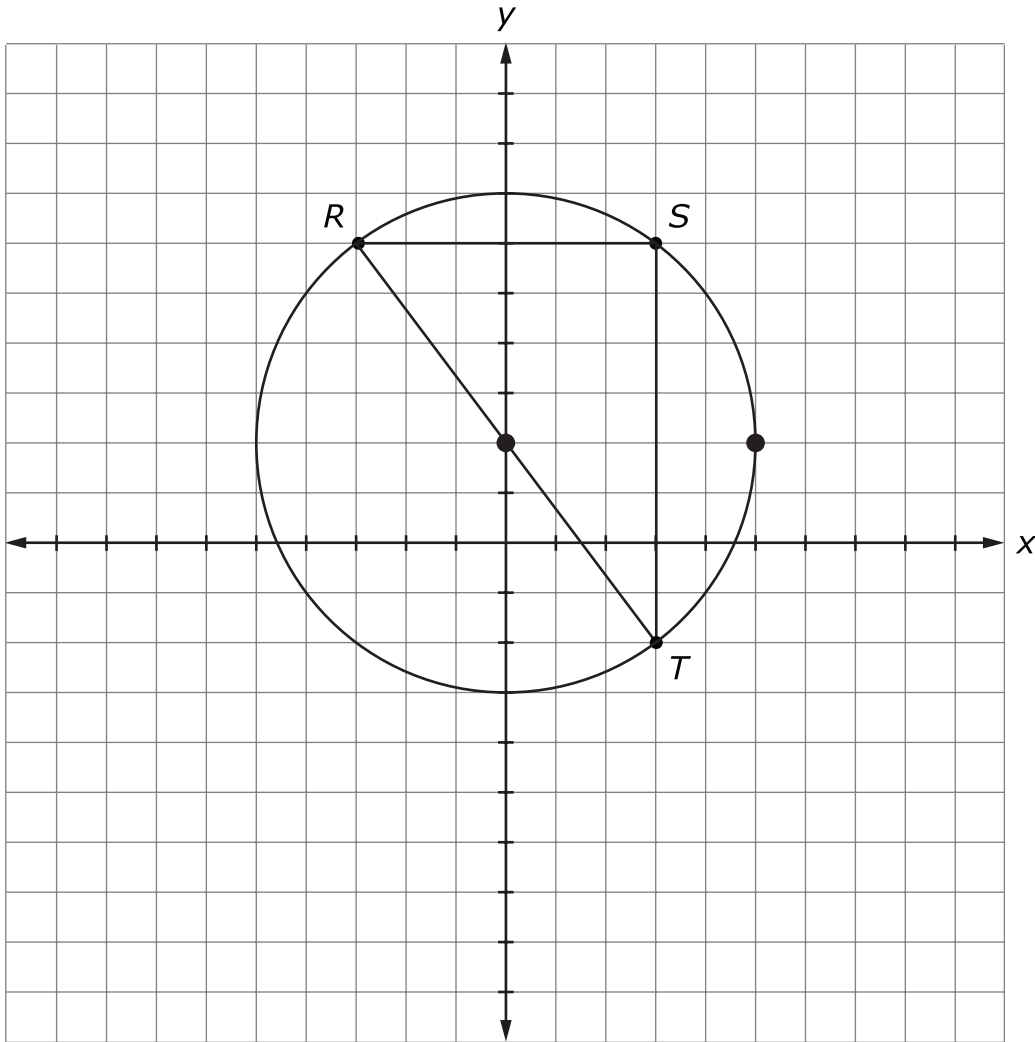

12. A B C D

13. A B C D E

14. 25

15. A B C D

16. $\frac{2m}{p}$

17. A B C D

18. A B C D

19. A B C D

20. 19

21. 1. A B C D

2. A B C D

3. A B C D

22. 0.8

Subpart 3 Practice Test Questions

23. 1. A B C D E

2. A B C D E

3. A B C D E

4. A B C D E

5. A B C D E

24.

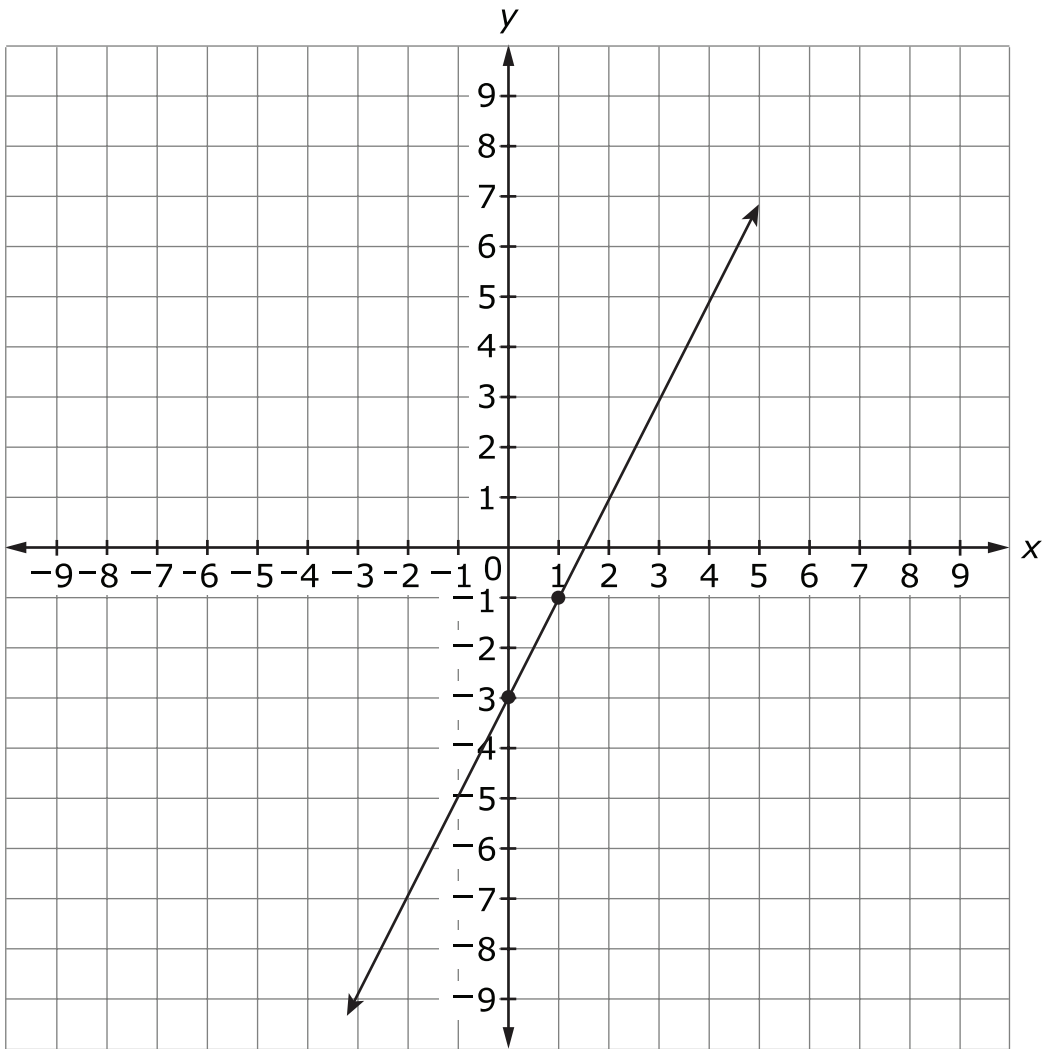

25. 41

26.

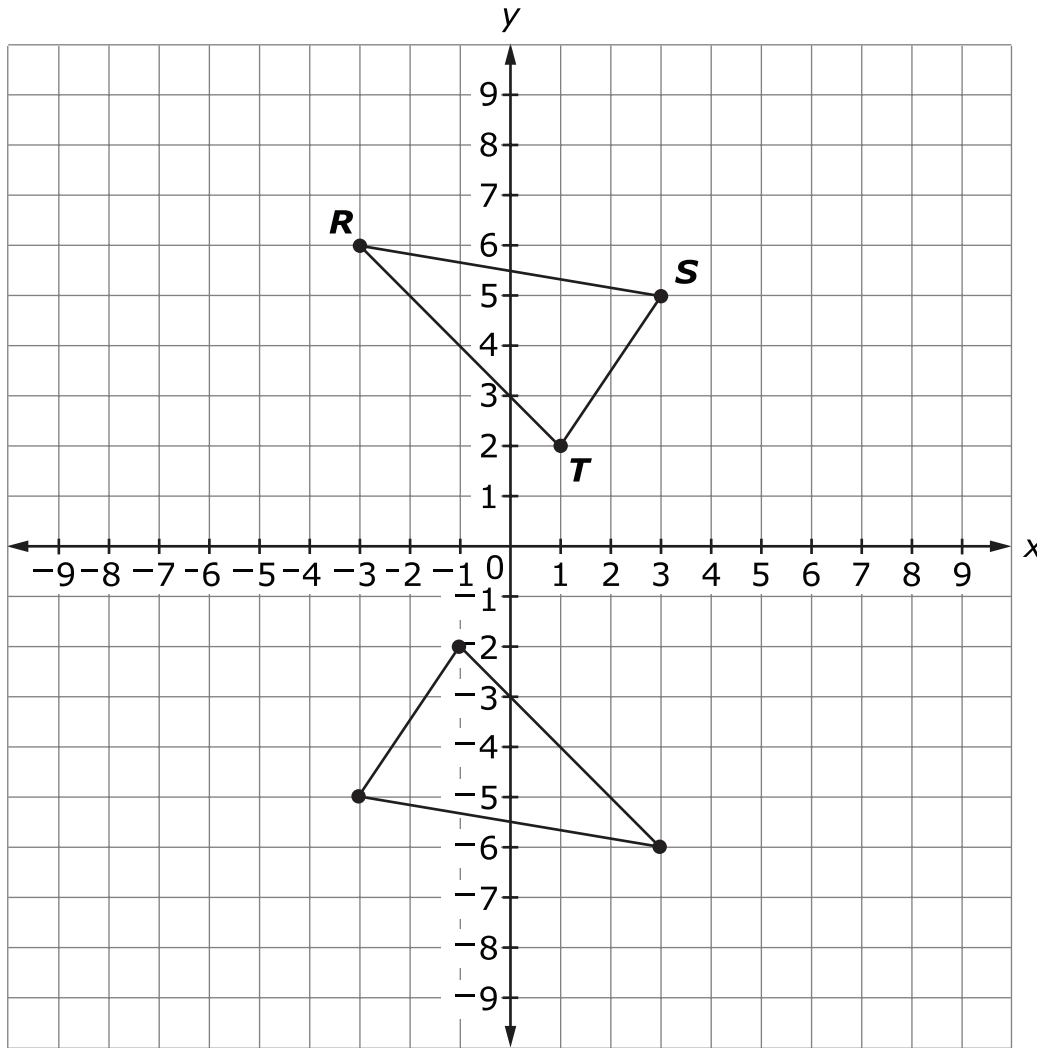

27. 249

28. (A) ● (C) (D)

29.

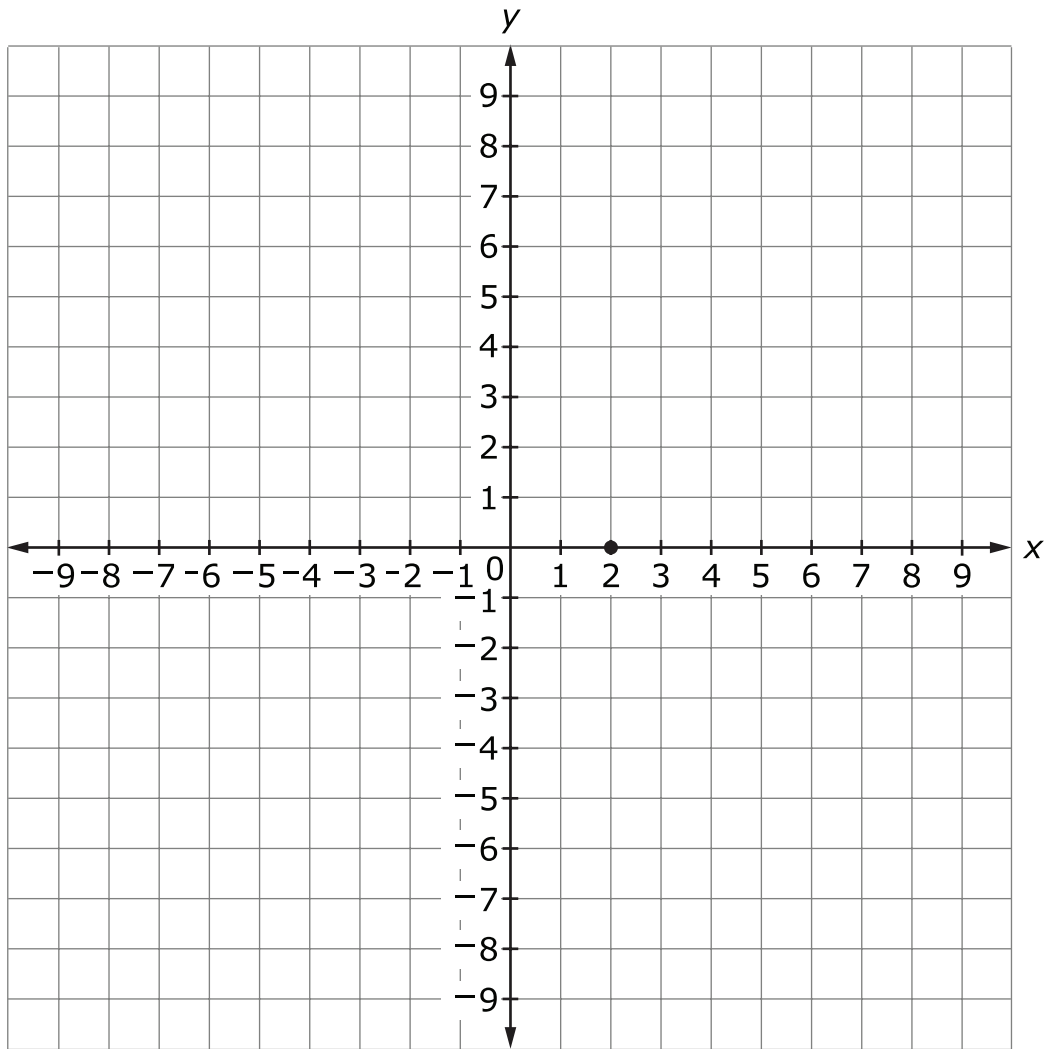

30. 6